

**CHF BC**



**TRAIL APPLIANCES**

**WELCOME PACKAGE**

# TRAIL APPLIANCES - WELCOME PACKAGE

---

## CHF BC

### *Members Welcome Package*

Within this package, you will find information on:

1. Welcome to Trail note
2. Brief Trail Appliances History
3. Contact Information
4. Ordering Procedure
5. Credit Application Process & Form
6. Appliances – Models and Pricing
7. Specifications on each model supplied to CHF BC members
8. Delivery Information for
  - (a) Lower Mainland
  - (b) Vancouver Island
  - (c) Thompson Okanagan
  - (d) Kootenay and Northern BC
9. How to request service
10. How to locate Model and Serial Numbers
11. Extended Service Coverage



# TRAIL APPLIANCES - WELCOME PACKAGE

---

*Welcome to Trail*

**Valued CHF BC Member,**

Trail Appliances is proud to be part of the CHF BC team of specialized and dedicated contractors; this is a designation we have sought after for a number of years. We have worked closely with the CHF BC Directors and our Suppliers to determine a package of appliances specially designed to meet your apartment replacement needs. We are pleased to be able to offer these appliances at significant discounts. The pricing provided is specific to CHF BC Members and you will not see this advertised in any of our locations. We are saving these discounts just for you!

We have assembled a team of dedicated appliance professionals that are ready to assist with all of your appliance needs. Norm Turnbull, our Account Manager and Elizabeth O'Connor, our Builder Administrator, have extensive experience with apartment replacement and contractor sales. They have all of the tools to meet your expectations.

Trail Appliances prides itself on providing industry leading service. Now that we have been awarded the CHF BC contract for the next 3 years (and hopefully more to come), we have begun taking the necessary steps to take our level of service even further. This includes updating our website to allow for enhanced ordering capabilities.

We are very excited to be partnered with CHF BC and look forward to many years of successful partnership. Thank you in advance for choosing Trail as your appliance provider.

Sincerely,

Tony Goodale  
Builder Manager – Multi Family Division  
Trail Appliances



# TRAIL APPLIANCES - WELCOME PACKAGE

---

## *History*

Trail Appliances is a family owned and operated business. We opened our first location in 1974 on Macleod Trail in Calgary and since then have expanded to 8 locations throughout British Columbia and 6 in Alberta, and 1 in Saskatchewan. Trail currently has over 20 Broderick family members working throughout all levels of the company. Our Trail “Family” is over 700 strong.

In the Lower Mainland, we have proudly kept all Sales, Delivery and Parts and Service roles in house. This has allowed for complete vertical integration and allowed us to monitor and control all aspects of our business. As a fully self sufficient company, we can ensure the customer experience is as efficient and seamless as possible.

We attribute our success and growth to the Trail way!

**T** – Trust. It is our goal to earn the trust of every client

**R** – Respect. Treat every client with the utmost respect

**A** – Allegiance. Build strong, long lasting partnerships

**I** – Integrity. Act in our clients best interest

**L** – Loyalty. Ensure our clients feel comfortable coming back to us.

We are the largest dealer in Western Canada for LG, Kitchenaid, Whirlpool and Bosch. We are also the largest dealer in Canada of Brigade, Miele, Dacor and Thermador. Combined with the over 40 brands we supply, allows us to obtain additional discounts from suppliers which we pass on to our clients. This has allowed us to be aggressive and offer CHF BC Members extended discounts of off the models listed.

Our showrooms are strategically placed throughout the Lower Mainland, Victoria and Kelowna. We offer a unique display with live, fully operation kitchens allowing the client to actually touch and play with the product before purchase.

Our apartment replacement specialists and dedicated Builder Team are available for training and information. If requested, we will visit your sites and help train individuals how to properly use our products.



# TRAIL APPLIANCES - WELCOME PACKAGE

---

## *Contact Information*

**For questions or concerns regarding Sales, product or delivery:**

Norm Turnbull - *Apartment Replacement Specialist*

Cell: (604)992-7124

Store: (604)534-7461

Fax: (604)534-7468

Email: [apreplacement@trailappliances.com](mailto:apreplacement@trailappliances.com)

Elizabeth O'Connor - *Builder Administrator*

Store: (604)534-7461

Fax: (604)534-7468

Email: [apreplacement@trailappliances.com](mailto:apreplacement@trailappliances.com)

**For service on your appliances, please call:**

Trail Appliances - *Service Call Centre*

Office: (604)777-3300 (Ext 2)



# TRAIL APPLIANCES - WELCOME PACKAGE

---

## *Ordering Procedure*

**For your convenience, your appliance order may be submitted by any of the following methods:**

**Phone:** Norm Turnbull -Builder Sales and Elizabeth O'Connor - Builder Administrator can be reached at our Langley Office at **(604) 534-7461**.

**Fax:** You can fax your order to the attention of Norm Turnbull and Elizabeth O'Connor at **(604) 534-7468**. Please use the order form found within this package.

**Email:** Email the request to **apreplacement@trailappliances.com**. Please use the order form found within this package.

**Please have the following information ready when submitting your request:**

- |                   |                                   |
|-------------------|-----------------------------------|
| 1. Your Account # | 3. Contact information            |
| 2. Account Name   | 4. Billing and Shipping Addresses |



# TRAIL APPLIANCES - WELCOME PACKAGE

---

## *Credit Process*

CHF BC Member,

Thank you very much for choosing Trail Appliances Ltd.

To apply for a Net 30 terms account, please contact our Credit Department. They can be reached by email at **creditdept@trailappliances.com** or by fax or phone to the contact listed below. Please be sure to provide:

The contact person's name, mailing address, email and fax number.

The Credit Department will in turn send out the appropriate Credit application to be completed. Upon return of the signed and completed application, we will endeavour to have completed our credit review within two weeks and advise of the outcome.

Our Credit Department is happy to work with scanned copies of the Credit Application in the interim; however we do require that the signed original be returned, so please also mail the hard copy of the original back as soon as possible to our Credit Department at:

Teresa Schultz  
Assistant Credit Manager  
Trail Appliances  
5400 Minoru Boulevard  
Richmond, BC  
V6X 2A9  
Fax: 604-278-3049

Thank you and we look forward to working with you.

Sincerely,

Builder Management



# TRAIL APPLIANCES - WELCOME PACKAGE

## *Delivery Information*

We would appreciate as much notice as possible, to allow for truck scheduling, product availability and shop work such as door swings, if required. We do understand however, that with Apartment Replacement, your tenant's non-working fridge is a priority and we will do our best to arrange next day service, providing your order is placed by 11am.

For urgent deliveries, please fax (604) 534-7468 your order, followed by a call to Elizabeth O'Connor, the Builder Administrator at (604) 534-7461 to ensure receipt of your priority request.

### Delivery Information by Territory

	Lower Mainland	Vancouver Island	Thompson Okanagan	Kootenay Region & Northern BC
Hours of Operation:	Monday - Saturday	Tuesday - Saturday	Tuesday - Saturday	Please call for details.
Pricing:	<ul style="list-style-type: none"> <li>• 1st Piece \$40</li> <li>• Additional Appliance to the same address \$15/pc</li> <li>• Haul Away \$15/pc</li> <li>• Install laundry \$65/Suite</li> </ul>	<ul style="list-style-type: none"> <li>• 1st Piece \$40</li> <li>• Additional Appliance to the same address \$15/pc</li> <li>• Haul Away \$15/pc</li> <li>• Install laundry \$65/Suite</li> </ul>	<ul style="list-style-type: none"> <li>• 1st Piece \$40</li> <li>• Additional Appliance to the same address \$15/pc</li> <li>• Haul Away \$15/pc</li> <li>• Install laundry \$65/Suite</li> </ul>	Please call for a quote.
Additional Comments:	Excluding Statutory Holidays. We cannot provide an exact time but can offer a AM or PM delivery window.	Excluding Statutory Holidays. We cannot provide an exact time but can offer a AM or PM delivery window.	Excluding Statutory Holidays. We cannot provide an exact time but can offer a AM or PM delivery window. Trail delivers to Kelowna & Westbank, however we outsource our deliveries to Kamloops, Penticton & Salmon Arm.	We understand the urgency in delivering appliances required for this region and because we have a great relationship with Van Kam & Canadian Freightways, we are able to accommodate such requests.

In the Lower Mainland, Vancouver Island & the Thompson Okanagan our drivers will uncrate and set your appliances in place, taking the packaging with them when they leave. Please ensure that exiting appliances are disconnected, emptied and that there is clear access into the unit prior to the truck's arrival.

Your new appliances will be uncrated and inspected for your approval on site. In the event of any damages, an allowance, repair or replacement will be arranged. Should you require removal of an old appliance, please indicate so on the order form.





# TRAIL APPLIANCES - WELCOME PACKAGE

---

## *How to Request Service*

If you require service on your appliance, please call the Trail Service Call Centre (604) 777-3300 to book a service call with a Technician. So that our Service Representatives can better assist, please have the following information ready:

1. Account Name:
2. Account No.:
3. Home Address:
4. Model No. (See below for further instructions)
5. Serial No. (See below for further instructions)
6. Date of Delivery:

### **Where to Find Model & Serial Numbers on Appliances**

#### Cooking Products

- Range: Inside the oven section, on the top edge, where the door meets the lip of the oven cavity or, inside the drawer, at the top of the frame surrounding the cavity.
- Cooktops: Underneath the unit on the back.
- Wall Ovens: At the top left or right of the inside rim, in front of the cavity.

#### Refrigerators

- Fridges: Anywhere at eye level to the left or right of the door in the refrigerator compartment.
- Bar Fridges: On the outside, at the back of the appliance, not displayed on the interior of the fridge.
- Wine Coolers: On the outside, at the back of the appliance, not displayed on the interior of the fridge.

#### Dishwashers

- Either on the top of the outermost surface of the cavern or on the right or left side, just inside the opening.

#### Ventilation

- Hoodfans: On the underside of the hoodfan, near the back.
- Hoodfan/Microwave: On the inside of the microwave, on the lip of the microwave interior doorframe.

#### Laundry

- Washers: Top Loader, on the underside of the lid or affixed centrally inside the tub rim & Front Loader, on the interior rim of the door.
- Dryers: Top Loader, on the underside of the lid or affixed centrally inside the tub rim & Front Loader, on the interior rim of the door.
- Stackers: On the inside of the dryer, on the side of the dryer door.

**Please Note:** Your new appliances come with a one year manufacturer's warranty against defects in materials or workmanship, unless otherwise specified in your product manuals. If your manufacturer's warranty has expired the service call will be subject to a diagnostic charge & any other applicable charges required to repair your appliance. If your appliance is covered under the manufacturer's warranty, but the service call is determined to be user error or customer education, a diagnostic charge will be issued. To avoid this, please read your use & care manual thoroughly prior to requesting service.



# TRAIL APPLIANCES - WELCOME PACKAGE

## *Extended Service Coverage*

BRAND	WARRANTY LENGTH
Whirlpool	1 Year
Frigidaire	1 Year
Danby	1 Year
Broan	1 Year
Wasteking	1 Year

### Peace of Mind with Extended Product Warranty Coverage

If you've ever had to call for service on an out-of-warranty appliance you'll know that it can be costly. Even if you choose not to have the appliance repaired, there is still a charge for having a Service Technician come to your home.

With an extended warranty from Trail Appliances, you have of peace of mind, knowing that if your appliances need a helping hand, all you need to do is call us. We'll arrange a time to come to your home, diagnose and fix the problem, all at no extra cost to you. Choose either a one or four year extended warranty package, whichever best suits your needs.



Here are just a few reasons as to why you would benefit from an extended warranty:

1. Appliances have evolved and have more and more components that are costly to repair. Rest easy knowing that you are covered in the event of a breakdown.
2. All repair service for major appliances will be provided in-home by an authorized service technician.
3. Just one service call over the term of the warranty can virtually pay for the value of the warranty purchase.
4. Up to \$200 worth of food replacement if food spoilage occurs if your fridge or freezer breaks down (4 year plan only).
5. We'll repair your appliance and make it as good as new.
6. If there are three identical failures on a covered product after the manufacturer's warranty has expired, your product may be replaced or you will receive a prorated credit on the value of the appliance.
7. If you are planning on selling your home, coverage can either move with you or be transferred to a new owner.
8. If you are a Landlord and are renting out your home, this is an excellent way to protect your investment.

### How to Purchase an Extended Product Warranty from Trail Appliances

Simply contact Norm Turnbull - Builder Sales for CHF BC at (604)534-7461





## Order Form

### Trail Appliances CHF BC Appliance List



\*TAXES NOT INCLUDED - Price list valid until Dec 31, 2013

REFRIGERATORS	BRAND	SPECS and Model #	Dimensions	Enviro Fee	Select ✓	Door Swing	Haul Away ✓
12 CU FT, 2 DOOR	Whirlpool	DFE1144W	D:27", H:61", W:24"	\$1.25		L / R	
15 CU FT, 2 DOOR	Whirlpool / Inglis	W5TXDWFQXQ (estar)	D:31.5", H:63", W:28"	\$1.25		L / R	
18 CuFt Glass Shelf	Whirlpool	WRT138TFYW (estar)	D:32 3/4", H:66 1/4", W:29 1/2"	\$1.25		L / R	
18 CU FT, 2 DOOR- <b>GOOD</b>	Amana	A8RXCQFXW	D:33", H:68", W:28"	\$1.25		L / R	
18 CU FT, 2 DOOR- <b>BETTER</b>	Whirlpool	W8RXCQFXQ	D:31.5", H:68", W:28"	\$1.25		L / R	
19 CFT BOTTOM FREEZER	Whirlpool	EB9FVBXWQ - SWING DOOR	D:32 3/4", H:66 1/4", W:29 1/2"	\$1.25		L / R	
19 CFT BOTTOM FREEZER	Whirlpool	EB9FVHXWQ - DRAWER	D:32 3/4", H:66 1/4", W:29 1/2"	\$1.25		L / R	
ELECTRIC RANGES	BRAND	SPECS and Model #	Dimensions	Enviro Fee	Select ✓	N/A	Haul Away ✓
24"-MANUAL CLEAN	FRIGIDARE	CMEF212ES	D:26", H:48", W:24"	\$1.10		N/A	
24" SELF-CLEAN	FRIGIDARE	CFEF2415LW	D:26", H:48", W:24"	\$1.10		N/A	
30" MANUAL CLEAN	Whirlpool	YWFC150M0AW	D:27", H:47", W:30"	\$1.10		N/A	
30" SELF-CLEAN - <b>GOOD</b>	Whirlpool	YWFC310S0BW	D:25", H:47", W:30"	\$1.10		N/A	
30" SELF-CLEAN - <b>BETTER</b>	Whirlpool	YWFE510S0AW	D:27", H:47", W:30"	\$1.10		N/A	
GAS RANGES	BRAND	SPECS and Model #	Dimensions	Enviro Fee	Select ✓	N/A	Haul Away ✓
30"	Whirlpool	WFG231LVQ / WFG540H0AW	D:27", H:46.25", W:30"	\$1.10		N/A	
DISHWASHERS	BRAND	SPECS and Model #	Dimensions	Enviro Fee	Select ✓	N/A	Haul Away ✓
18" BUILT-IN	Whirlpool	DDW1809W	See Spec attached	\$1.10		N/A	
24" BUILT-IN	Whirlpool	WDF310PAAW	See Spec attached	\$1.10		N/A	
HOOD FANS	BRAND	SPECS and Model #	Dimensions	Enviro Fee	Select ✓	N/A	Haul Away ✓
24"	BROAN	BP124WHN	See Spec attached	\$1.10		N/A	
30"	BROAN	BP130WWN	See Spec attached	\$1.10		N/A	
30"	BROAN	QS130WWN	See Spec attached	\$1.10		N/A	
GARBURATORS -	BRAND	SPECS and Model #	Dimensions	Enviro Fee	Select ✓	N/A	Haul Away ✓
HOUSEHOLD DISPOSER - 1/3 hp	WASTEKING	111	See Spec attached	\$1.10		N/A	
HOUSEHOLD DISPOSER - 1/2 hp	WASTEKING	1001	See Spec attached	\$1.10		N/A	

### Please complete the following





PO #: \_\_\_\_\_ Billing Address: \_\_\_\_\_  
 Account Name: \_\_\_\_\_ Shipping Address: \_\_\_\_\_  
 Contact Name: \_\_\_\_\_ Shipping Address Cont': \_\_\_\_\_  
 Contact Phone #: \_\_\_\_\_ Requested Date: \_\_\_\_\_

### Laundry pricing & installation available upon request.

Please note that with the exception of laundry, Trail Appliances does not perform installations of appliances. If installation is required we recommend Han Appliances. Han Appliances can be reached at 604-233-9216 to arrange services directly & to discuss rates. If you would like us to contact Han Appliances on your behalf to request that they contact you for installation services, please make indicatoin in the note space provided below.

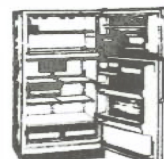
Delivery \$40 first Piece, 2nd piece thereafter is \$15. Haul Away fee \$15/Piece

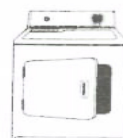
Please fax the completed form to the attention of Norm Turnbull and Elizabeth O'Connor at (604)534-7468  
 This form can also be emailed to [apreplacement@trailappliances.com](mailto:apreplacement@trailappliances.com)

<b>FRIDGE DOOR SWING</b>  Left Hand		 Right Hand	
<b>WASHER DOOR SWING</b>  Left Hand		 Right Hand	
<b>DRYER DOOR SWING</b>  Left Hand		 Right Hand	

## TRAIL APPLIANCES - PACKAGE

---

Please note that the following appliance dimensions are for planning purposes only. Please consult the installation instructions with each product before cutting cabinets or countertops.

All models and specifications are subject to change.





**DFF1144W**

11 Cu Ft White Top Mount Fridge



**FEATURES**

- 11 cu.ft. capacity refrigerator
- Frost-free operation
- Mechanical thermostat
- Crystal vegetable crisper with glass cover
- Tall bottle storage
- 3 adjustable wire shelves for maximum storage versatility
- Integrated door shelf and egg compartment
- Interior light
- Reversible door hinge
- Integrated handle

**DIMENSIONS**

Width:	23.94"
Depth:	29"
Height:	59.56"

**WARRANTY**

Please see use and care manual for complete warranty information.



Product Representation, specifications and dimensions are for planning purposes only.  
For complete information, please see installation instructions packed with product



**W5TXDWFXQ**

1.5 cu.ft. Whirlpool® Top-Freezer Refrigerator



### FEATURES

- Temperature Control
- Reversible Doors
- Frost Free
- Energy Star Qualified
- Shelf Suspension
- One Crisper
- One dairy compartment
- Wire shelves

### DIMENSIONS

Width:	28"
Depth:	31.13"
Height:	62.75"

### WARRANTY

#### ONE YEAR LIMITED WARRANTY

For one year from the date of purchase, when this major appliance is operated and maintained according to instructions attached to or furnished with the product, Whirlpool Corporation or Whirlpool Canada LP (hereafter "Whirlpool") will pay for FSP® replacement parts and repair labour to correct defects in materials or workmanship. Service must be provided by a Whirlpool designated service company.



Product Representation, specifications and dimensions are for planning purposes only.  
For complete information, please see installation instructions packed with product



**WRT138TFYW**  
18 cu. ft. Top-Freezer Refrigerator



**FEATURES**

- Up-Front Temperature Controls
- Accu-Chill™ Temperature Management System
- Adaptive Defrost System
- Humidity-controlled Crisper Bins
- SpillMizer™ Glass Shelves
- Clear Meat Pantry
- ADA Compliant
- 2008 Energy Star (20%) 388kWh/yr

**DIMENSIONS**

Width: 29 1/2"  
Depth: 32 3/4"  
Height: 66 1/4"

**WARRANTY**

**ONE YEAR LIMITED WARRANTY**

For one year from the date of purchase, when this major appliance is operated and maintained according to instructions attached to or furnished with the product, Whirlpool Corporation or Whirlpool Canada LP (hereafter "Whirlpool") will pay for FSP® replacement parts and repair labour to correct defects in materials or workmanship. Service must be provided by a Whirlpool designated service company.



Product Representation, specifications and dimensions are for planning purposes only.  
For complete information, please see installation instructions packed with product

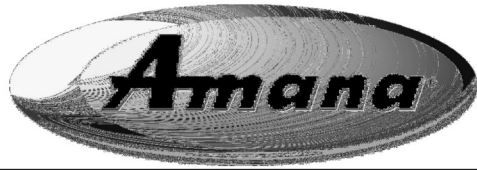

## A8RXCGFXW

18 cu. ft. Top-Freezer Refrigerator



### FEATURES

- Contoured Doors
- Up-Front Temperature Control System
- Interior Light
- 2 Full-Width Adjustable Spillsaver™ Glass Shelves
- 2 Garden Fresh™ Crisper Drawers
- Gallon Door Storage
- 2 Full-Width, 1 Half-Width Fixed Door Shelves
- Deli Drawer
- Dairy Centre
- Wire Freezer Shelf
- 2 Fixed, Full-Width Freezer Door Shelves

### DIMENSIONS

Width:	28"
Depth:	31"
Height:	68"

### WARRANTY

Limited One Year Warranty - Parts and Labour. For one (1) year from the original retail purchase date, any part which fails in normal home use will be repaired or replaced free of charge. Refer to the Use and Care for warranty details







**W8RXCgfxQ**  
18 cu.ft. Top-Freezer White Refrigerator



#### FEATURES

- Capacity: 18 cu. ft.
- Up-Front Temperature Controls
- Clear Humidity-Controlled Crispers: 2
- Meat pan
- SpillMizer™ glass shelves
- Contour door
- Integrated handle
- Reversible Doors

#### DIMENSIONS

Height :	68"
Width:	28"
Depth:	31 1/2"

#### WARRANTY

##### ONE YEAR LIMITED WARRANTY

For one year from the date of purchase, when this major appliance is operated and maintained according to instructions attached to or furnished with the product, Whirlpool Corporation or Whirlpool Canada LP (hereafter "Whirlpool") will pay for FSP® replacement parts and repair labour to correct defects in materials or workmanship. Service must be provided by a Whirlpool designated service company.





**EB9FVBXWQ**

18 cu.ft. Whirlpool® Bottom-Freezer Refrigerator



### FEATURES

- EZ-View™ Plus Humidity-Controlled Crispers
- AccuChill™ Temperature Management System
- Up-Front Temperature Controls
- Optional ice maker
- Automatic defrost system
- Half-Width Spillguard™ Glass Shelves: 2
- Door bins: 5
- Clear Dairy Compartment
- Clear meat pan
- Reversible Door Swing: (EB9FVBXWB/Q)
- Full-width Freezer Basket
- Freezer Light
- ENERGY STAR® Qualified
- EnerGuide Rating: 448 kWh per year
- Flat smooth door

### DIMENSIONS

Width:	29 5/8"
Height:	67"
Depth:	34 3/8"

### WARRANTY

#### ONE YEAR LIMITED WARRANTY

For one year from the date of purchase, when this major appliance is operated and maintained according to instructions attached to or furnished with the product, Whirlpool Corporation or Whirlpool Canada LP (hereafter "Whirlpool") will pay for FSP® replacement parts and repair labour to correct defects in materials or workmanship. Service must be provided by a Whirlpool designated service company.





## EB9FVHXWQ

18 cu.ft. Whirlpool® Bottom-Freezer Refrigerator



### FEATURES

- Capacity: 18.5 cu. ft
- EZ-Vue™ Plus Humidity-Controlled Crispers
- AccuChill™ Temperature Management System
- Up-front Electronic Temperature Controls
- Automatic defrost system
- Split Spillguard™ Glass Shelves: 3
- EZ-Tote™ Adjustable Door Bins: 3
- Reversible Door Swing: (White and Black models only)
- Full-width Freezer Basket
- Drawer Bottom Freezer
- Freezer Light
- ENERGY STAR® Qualified
- EnerGuide Rating: 448 kWh per year

### DIMENSIONS

Width:	29 5/8"
Height:	65 5/8"
Depth:	32 1/2"

### WARRANTY

#### ONE YEAR LIMITED WARRANTY

For one year from the date of purchase, when this major appliance is operated and maintained according to instructions attached to or furnished with the product, Whirlpool Corporation or Whirlpool Canada LP (hereafter "Whirlpool") will pay for FSP® replacement parts and repair labour to correct defects in materials or workmanship. Service must be provided by a Whirlpool designated service company.



Product Representation, specifications and dimensions are for planning purposes only.  
For complete information, please see installation instructions packed with product

*Frigidaire*

**CMEF212ES**  
24" Freestanding Range



**FEATURES**

- Easy Clean
- Metal Backguard
- Mechanical Oven Control
- TOD Timer
- 1 Outlet
- 6" 1250 Watts
- 6" 2 x 1500 Watts
- 8" 2400 Watts
- Black Porcelain Drip Bowls
- Oven Light
- 2 Oven Racks
- Regular Window

**DIMENSIONS**

Width: 24"  
Depth: 26"  
Height: 48"

**WARRANTY**

Full One year warranty for defects in manufacturer's materials or workmanship. See product manual for details.



Product Representation, specifications and dimensions are for planning purposes only.  
For complete information, please see installation instructions packed with product

*Frigidaire*

**CFEF2415LW**

24" Self Clean Electric Range



**FEATURES**

- Self Cleaning
- Oven Controls
- Plastic Knobs
- Metal Handle
- Coil Cooktop with Black Porcelain Burner Bowls
- 2.9 Cu. Ft Self Clean Oven
- Glass Visualite Door with Regular Window
- Storage Drawer with Integrated Handle
- 1 x Oven Light
- 2 x Racks
- 1 x Appliance Outlet

**DIMENSIONS**

Width: 24"  
Depth: 26"  
Height: 48"

**WARRANTY**

Full One year warranty for defects in manufacturer's materials or workmanship. See product manual for details.



Product Representation, specifications and dimensions are for planning purposes only.  
For complete information, please see installation instructions packed with product



**YWFC150M0AW**

30" 4.8 cu. ft. Capacity Electric Range



### FEATURES

- Upswept Porcelain SpillGuard™ Cooktop
- 2 Adjustable Oven Racks
- Lower Storage Drawer
- Custom broil
- 2 Oven Racks
- Oven Light
- 4 Elements
- Oven Control

### DIMENSIONS

Width: 29 7/8"  
Depth: 27 3/4"  
Height: 46 7/8"

### WARRANTY

#### ONE YEAR LIMITED WARRANTY

For one year from the date of purchase, when this major appliance is operated and maintained according to instructions attached to or furnished with the product, Whirlpool Corporation or Whirlpool Canada LP (hereafter "Whirlpool") will pay for FSP® replacement parts and repair labour to correct defects in materials or workmanship. Service must be provided by a Whirlpool designated service company.



Product Representation, specifications and dimensions are for planning purposes only.  
For complete information, please see installation instructions packed with product



## YWFC310S0BW

30" Freestanding Electric Range



### FEATURES

- AccuBake® Temperature management system
- Delay Bake
- Keep Warm Function
- Self Cleaning
- 4.8 cubic ft
- Oven Light

### DIMENSIONS

Width : 29 7/8"  
Height: 46 7/8"  
Depth: 27 3/4"

### WARRANTY

#### ONE YEAR LIMITED WARRANTY

For one year from the date of purchase, when this major appliance is operated and maintained according to instructions attached to or furnished with the product, Whirlpool Corporation or Whirlpool Canada LP (hereafter "Whirlpool") will pay for FSP® replacement parts and repair labour to correct defects in materials or workmanship. Service must be provided by a Whirlpool designated service company.



Product Representation, specifications and dimensions are for planning purposes only.  
For complete information, please see installation instructions packed with product



**YWFE510S0AW**  
Freestanding 30" Self-Clean Ceran Range



**FEATURES**

- Electric freestanding range
- 4.8 cubic foot capacity
- Self clean
- AccuBake® cooking system
- Large window
- 4 stove-top elements
- Barrel-style knobs
- Storage drawer
- 2 standard oven racks

Create delicious family meals with the help of this 4.8 cu. ft. capacity electric range. The 9<sup>1</sup>/<sub>6</sub>" Dual Rapid Boil element lets you cook faster than ever by bringing liquids quickly to a boil. It also accommodates various sizes of cookware. The AccuBake® temperature management system delivers uniform baking results every time. A built-in sensor monitors oven temperature and controls the cooking elements. Automatically cleans the oven according to a preprogrammed cycle. The self-cleaning system requires no harsh chemicals or cleaners.

**DIMENSIONS**

Width:	29 7/8"
Depth:	27 3/4"
Height:	46 7/8"

**WARRANTY**

**ONE YEAR LIMITED WARRANTY**

For one year from the date of purchase, when this major appliance is operated and maintained according to instructions attached to or furnished with the product, Whirlpool Corporation or Whirlpool Canada LP (hereafter "Whirlpool") will pay for FSP® replacement parts and repair labour to correct defects in materials or workmanship. Service must be provided by a Whirlpool designated service company.







## WFG231LVQ

Whirlpool® 30" Standard Clean Freestanding Gas Range



### FEATURES

- Cast-Iron Grates
- 4.4 Cu. Ft. Oven Capacity
- (3) 7,000 BTU Burners
- 8,000 BTU Burner
- Center Griddle
- 7,500 BTU Fish Burner
- EasyView™ Extra-Large Oven Window
- Broiler Drawer

### DIMENSIONS

Depth	26 3/4"
Height	46 1/4"
Width	29 7/8"

### WARRANTY

#### ONE YEAR LIMITED WARRANTY

For one year from the date of purchase, when this major appliance is operated and maintained according to instructions attached to or furnished with the product, Whirlpool Corporation or Whirlpool Canada LP (hereafter "Whirlpool") will pay for FSP® replacement parts and repair labour to correct defects in materials or workmanship. Service must be provided by a Whirlpool designated service company.



Product Representation, specifications and dimensions are for planning purposes only.  
For complete information, please see installation instructions packed with product



**WFG540H0AW**  
White 30" Convection Gas Range



**FEATURES**

- 5.8 cubic foot capacity
- AccuBake® Temperature Management System
- 5,000 BTU AccuSimmer® burner
- 2 Oven Racks
- Oven Light
- 5 Burners
- 2 Grates
- TimeSavor™ convection cooking system
- New EasyView™ extra-large oven window
- AquaLift™ self-clean technology
- Energy Save Mode clock setting

**DIMENSIONS**

Width:	29 7/8"
Depth:	27 7/8"
Height:	46 7/8"

**WARRANTY**

**ONE YEAR LIMITED WARRANTY**

For one year from the date of purchase, when this major appliance is operated and maintained according to instructions attached to or furnished with the product, Whirlpool Corporation or Whirlpool Canada LP (hereafter "Whirlpool") will pay for FSP® replacement parts and repair labour to correct defects in materials or workmanship. Service must be provided by a Whirlpool designated service company.





**DDW1809W**

18" Full Console Dishwasher with 7 Wash Cycles



#### FEATURES

- 8 place setting capacity with silverware basket
- Simple electronic controls
- Durable stainless steel spray arm and interior
- Automatic detergent dispenser
- Energy Star compliant
- 6 wash cycles
- Rinse agent dispenser
- Built in water-softener system

#### DIMENSIONS

Width:	17 8/16"
Depth:	21 5/8"
Height:	32 8/16"

#### WARRANTY

12 months parts and labour coverage with In-Home service. Installation and/or Yearly Maintenance (cleaning) are not covered under warranty.



Product Representation, specifications and dimensions are for planning purposes only.  
For complete information, please see installation instructions packed with product



**WDF310PAAW**  
Dishwasher with ENERGY STAR®



**FEATURES**

- ENERGY STAR® Qualified
- Resource-efficient Wash System
- Auto Soil Sensor
- Tall Tub Design
- White Plastic Interior
- Quiet Partner™ I Sound Package
- Auto Soil Sensor
- Dynamic Fills
- Electronic Controls
- 4-Level SheerClean™ Direct Feed Wash System
- 3 Automatic Cycles
- 1-Hour Wash Cycle
- Heavy Wash Cycle
- Normal Cycle
- 4 Options
- High Temperature Wash System
- Heated Dry Option
- 4 Hour Delay Wash Option
- Control Lock
- Vinyl Racks
- In-Rack Silverware Basket
- 3 Cycles

**DIMENSIONS**

Width:	23 7/8"
Depth:	24 1/2"
Height:	34 1/2"

**WARRANTY**

**ONE YEAR LIMITED WARRANTY**

For one year from the date of purchase, when this major appliance is operated and maintained according to instructions attached to or furnished with the product, Whirlpool Corporation or Whirlpool Canada LP (hereafter "Whirlpool") will pay for FSP® replacement parts and repair labour to correct defects in materials or workmanship. Service must be provided by a Whirlpool designated service company.



Product Representation, specifications and dimensions are for planning purposes only.  
For complete information, please see installation instructions packed with product



**BP124WHN**  
24" Hoodfan



**FEATURES**

- 2-speed fan blade motor.
- 75-watt light with diffuser
- Four-way convertible; installs ducted 3 1/4" X 10" (vertical or horizontal), 7" round (vertical) and non-ducted. Non-ducted filter #FKM65 sold separately
- Includes 3 1/4" X 10" damper and adapter
- 7" round adapter and damper sold separately
- 180 CFM, 7.0 HVI 2100 Certified.

**DIMENSIONS**

Width:	24"
Depth:	18 1/4"
Height:	6"

**WARRANTY**

One Year Limited Warranty due to manufacturer's defect in materials or workmanship.

Please see product manual for full warranty details.





**BP130WWN**  
30" White Hoodfan



**FEATURES**

- 2-speed fan blade motor
- 75-watt light with diffuser (bulb not included)
- Four-way convertible: installs ducted 3 1/4" X 10" (vertical or horizontal), 7" round (vertical) and non-ducted. Non-ducted filter #FKM65 sold separately
- Includes 3 1/4" X 10" damper and adapter
- 7" round adapter and damper sold separately
- HVI 2100 Certified
- 120V, 1.7 Amps
- 7.0-7.5 Sones
- 180 to 210 CFM

**DIMENSIONS**

Width: 30"  
Depth: 18 1/4"  
Height: 6"

**WARRANTY**

One year limited warranty: During this one-year period, Broan-NuTone LLC will, at its option, repair or replace, without charge, any product or part which is found to be defective under normal use and service. Full details packed with product.





**QS130WWN**  
30" White Hoodfan



**FEATURES**

- Clean, sleek appearance
- Durable, baked-on polyester finish paint or brushed finish stainless steel
- Over 50% quieter than the average range hood
- Large, full filter design - dishwasher-safe for easy cleaning
- Dual halogen lights provide focused lighting for unmatched
- Cooktop visibility as well as a soft, night-time level (bulbs not included)
- Patented axial blade provides increased performance and quieter operation
- Flush-mounted controls
- Versatile design allows for 3 1/4" x 10" (83 mm x 254 mm), 7" (178 mm) round, or non-ducted discharges without re-positioning blower
- Adjustable duct connectors - accommodate off-center ductwork
- CleanSense™ charcoal filters change color when replacement is necessary (for non-ducted installations—purchase separately)
- Available in 30" (762 mm) width in White, Biscuit, Almond, Black, and Stainless Steel; 36" (914 mm) width in White and Stainless Steel
- Bi-lingual carton graphics and installation manual (English/French Canadian)

**DIMENSIONS**

Width: 30"  
Depth: 20"  
Height: 7 1/4"

**WARRANTY**

One Year Limited Warranty due to manufacturer's defect in materials or workmanship.

Please see product manual for full warranty details.





**111**  
Waste King Legend 111 • 1/3 Horsepower Disposer



**FEATURES**

- Space saving compact design
- High speed 1900 RPM Permanent Magnet Motor
- Corrosion resistant grinding components
- Fast and Easy mount system provides a no hassle installation
- Removable splash guard is included
- Safe for properly sized septic tanks
- Longest warranties in the industry
- Power cord included      Space saving compact design

**DIMENSIONS**

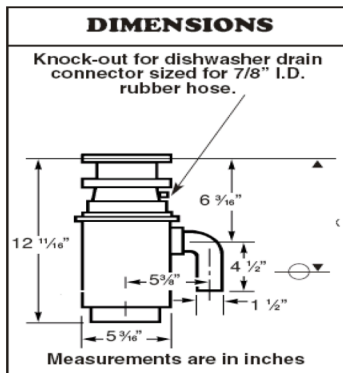

**WARRANTY**

2 Year In-Home Service Warranty







**Model 1001**  
1/2 Horsepower Disposer



**FEATURES**

- Space saving compact design
- High-speed 2600 RPM permanent magnet motor produces more power per pound
- Corrosion resistant grinding components
- Fast and Easy mount system provides a no hassle installation
- Removable splash guard is included
- Safe for properly sized septic tanks
- Longest warranties in the industry demonstrate commitment to quality

**DIMENSIONS**

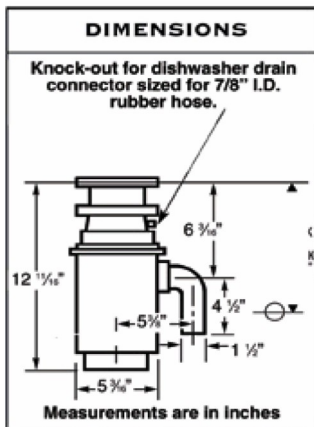

**WARRANTY**

2 year warranty against manufacturer's defects.

