



Model 1001
1/2 Horsepower Disposer



FEATURES

- Space-saving compact design
- High-speed 2600 RPM permanent magnet motor produces more power per pound
- Corrosion resistant grinding components
- Fast and easy mount system provides a no hassle installation
- Removable splash guard is included
- Safe for properly sized septic tanks
- Longest warranties in the industry demonstrate commitment to quality

DIMENSIONS

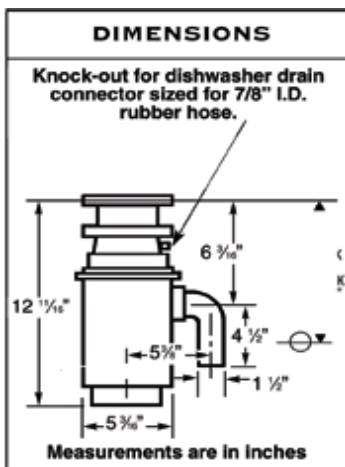

WARRANTY

2 year warranty against manufacturer's defects.

